

# LIST OF KIT ELEMENTS

## MOXA Set

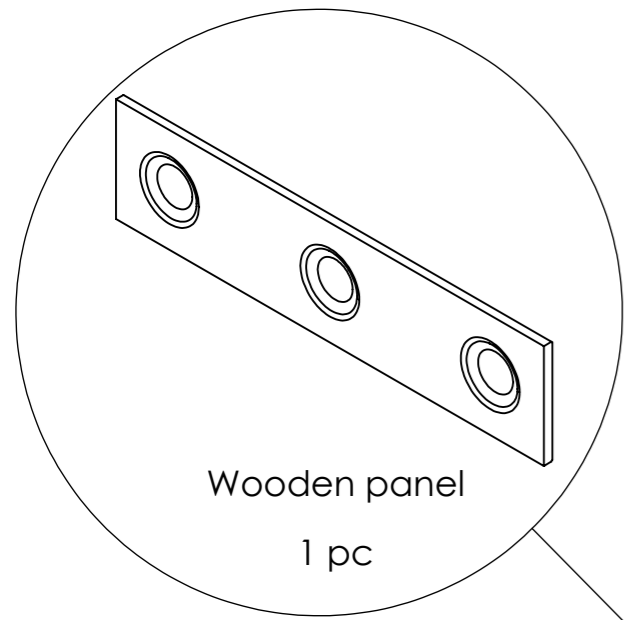

Wooden panel  
1 pc

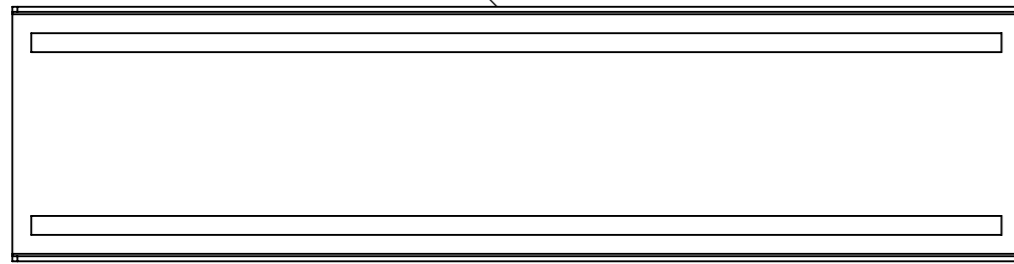

Metal Shelf of the Stand  
1 pc

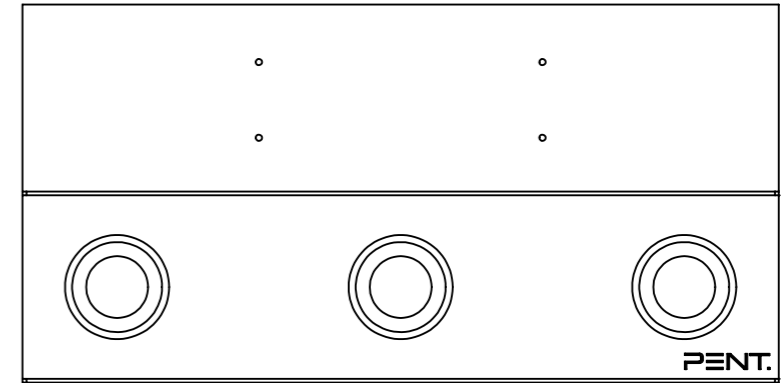

Base of the Stand with Bottom Metal Shelf  
1 pc

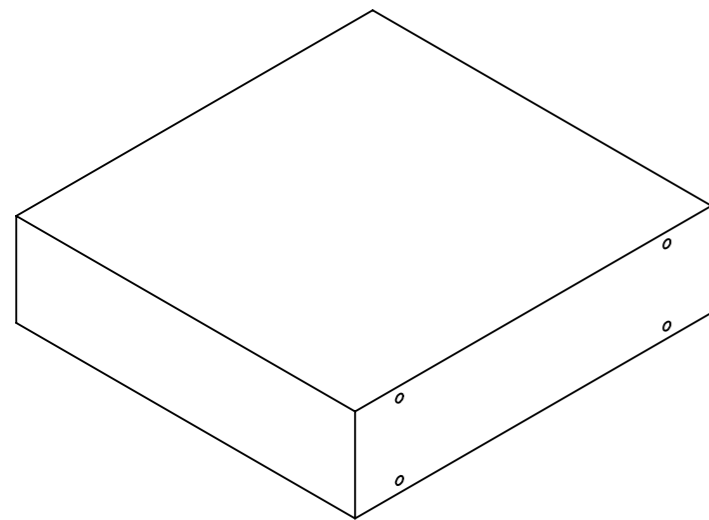

Leg of the Stand  
1 pc



Countersunk Head Screw  
M6x50 - 4 pcs  
M6x25- 4 pcs

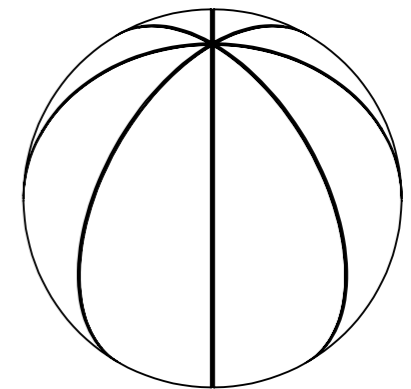

Weight Ball  
4 kg, 8 kg, 12 kg, 16 kg, 20 kg, 24 kg  
one each

## STEP 1

## STEP 2

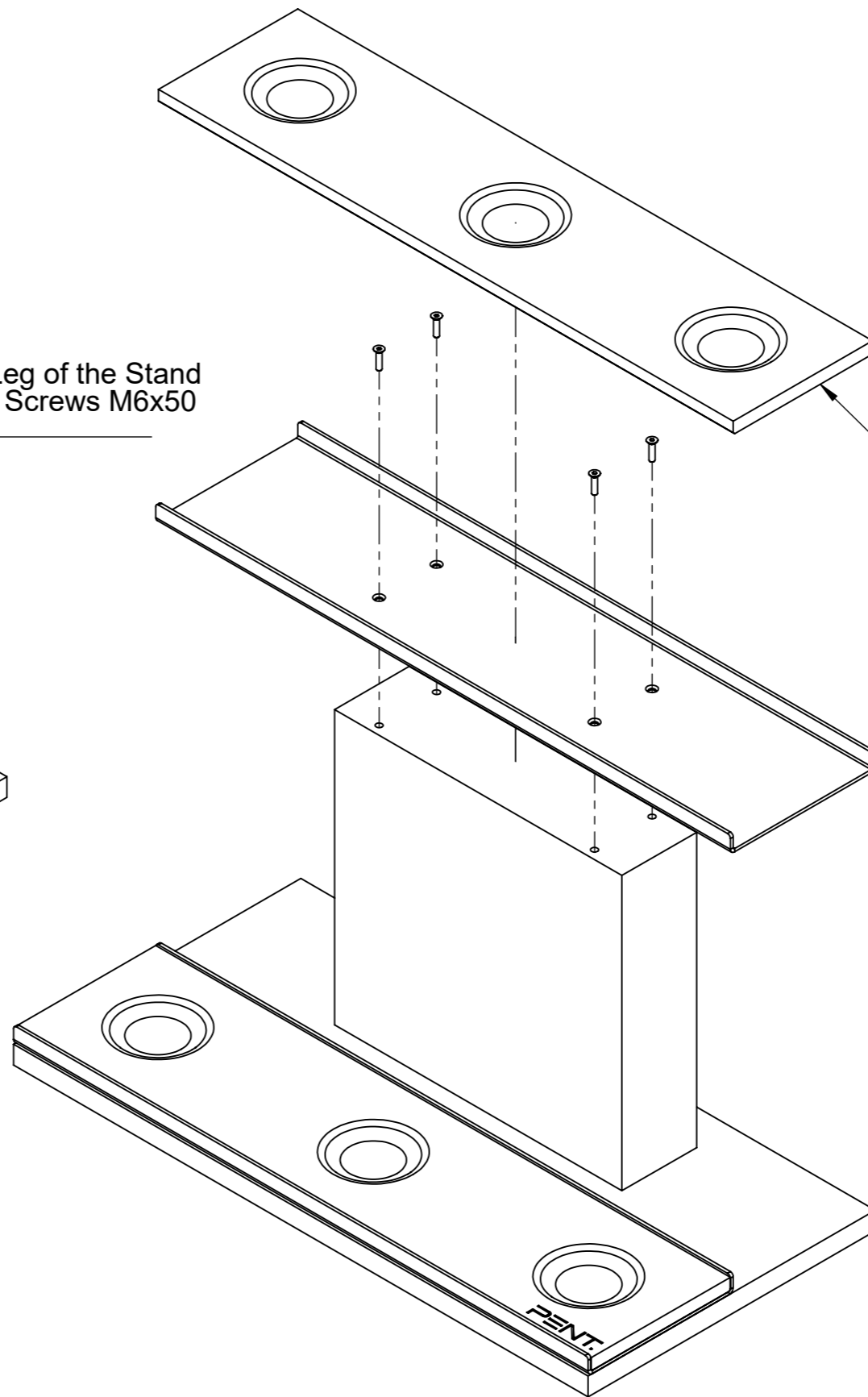
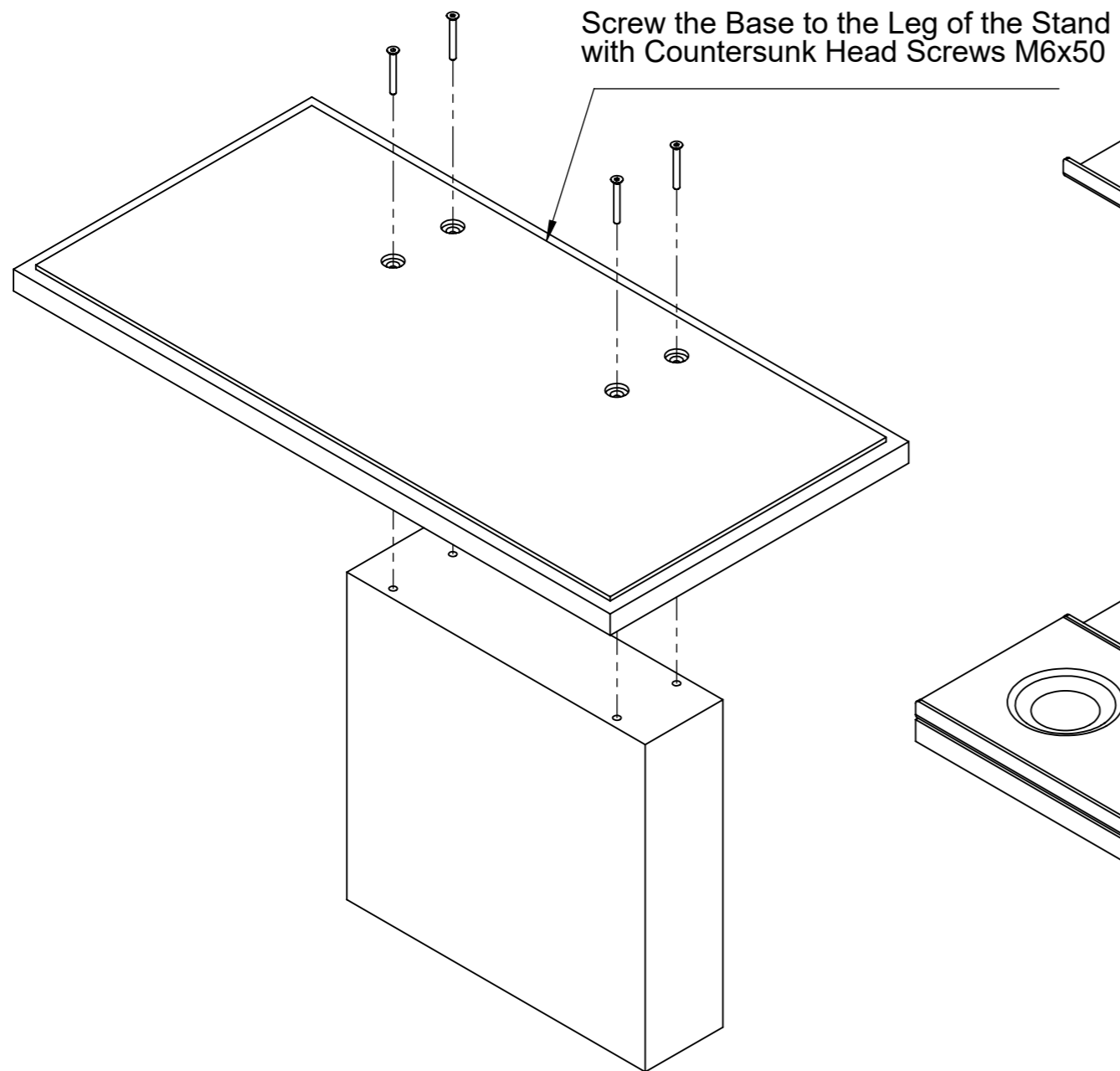

The Stand is delivered with Wooden Panels already on it.

Top Shelf mounting holes are located under the Wooden Panel placed upside down on the Top Shelf.

The Wooden Panel placed upside down need to be removed. Screw the Top Shelf with Countersunk Screws M6x30, then place the removed Wooden Panel on the Top Stand Shelf.

### STEP 3

Place the Weight Balls on  
Wooden Panels.  
Place the Weight Balls from the  
lightest on the Top Stand Shelf,  
to the heaviest on the Bottom  
Stand Shelf

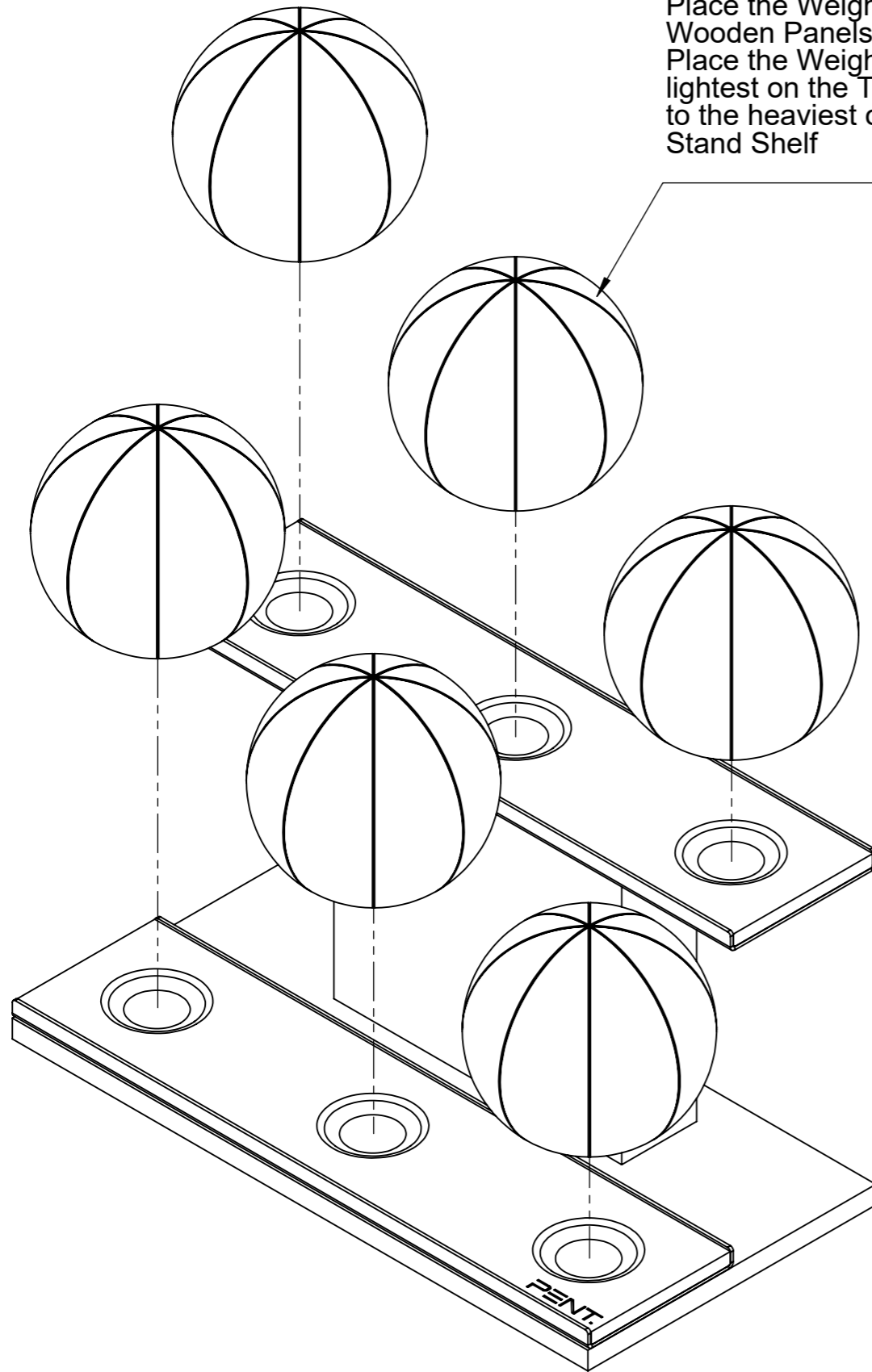

### FINISHED ASSEMBLY

